



川源（中国）机械有限公司  
GSD Industrial Co.,Ltd.

# SSP

## 沉水式不锈钢排水泵

**SSP stainless submersible sewage pump**



# SSP 沉水式不锈钢排水泵

## SSP stainless submersible sewage pump

### 用途

- 大楼地下排放设备，下水管排水工程。
- 土木建筑工程施工。
- 农业灌溉及畜牧排水。
- 船舱积水、污水排放。
- 污水处理场之污水输送。

### 特性

- 本产品采用不锈钢及工程塑胶为材质，重量轻。
- 本产品流道及叶轮一体成型，损失少、效率高，达到节省能源功能。
- 长期使用于一般污水中不生锈，不会产生二次污染，符合环保要求。
- 适用液体温度：0~40°C
- 机械轴封：双机械密封，轴封材质为碳化硅。
- 马达：鼠笼式感应电动机，F级绝缘并符合IP68。

### 标准配件

- 防水电缆5米
- 衔接凸缘：PP制一个
- 附出口排气阀
- 过热保护器

### 选择配件

- 自动着脱装置  
使泵浦安装保养修护迅速容易，毋须先清除桶槽污水
- 控制盘及浮球开关（3相）  
使泵浦可以交互并替操作
- 单相使用浮球开关
- 不锈钢材质，可依客户需求采用SUS316

### Applications

- Basement drainage, sewage drainage engineering.
- Construction engineering.
- Agricultural irrigation and livestock industry drainage.
- Discharges of accumulated water and sewage from ships.
- Transportation of sewage from sewage treatment terminal.

### Features

- Product material of stainless steel and industrial plastic, light in weight.
- Monoblock impeller and passageway, highly efficient with less energy loss, achieving energy saving purposes.
- No rusting and corrosion even after long period of operations, no secondary pollution, and complies with environmental protection requirement.
- Liquid temperature: 0~40°C
- Mechanical seal: double mechanical seals, material using for seal ring and floating seat is silicon carbide.
- Motor: squirrel cage induction motor, f class insulation and in accordance with IP68.

### Standard accessories

- Waterproof cable is in 5m length.
- Companion flange is made of PP+SPG.
- With outlet vent valve.
- Thermostat.

### Optional accessories

- AUTO-SETTER  
- to allow pump for easy installation, maintenance, and repair, as it is no need to empty tank first.
- CONTROL PANEL & FLOAT SWITCH  
- to allow automatic pump operations, enabling alternating and parallel operations also.
- Single phase operated float switch.
- Stainless steel made parts of pump may choose the use of SUS316, according to the customers' need.

### 型号说明 Type description

SSP - 5 0.4 - 50 (S)

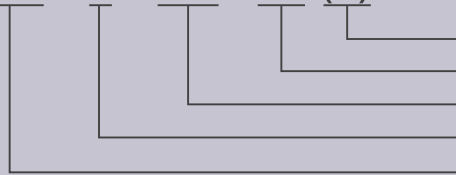

单相标示	Phase S : single
出口口径	Outlet diameter(mm)
额定功率	Rated power(kW)
频率	5:50Hz(Hz)
机型	Models type



## 结构简图 Construction

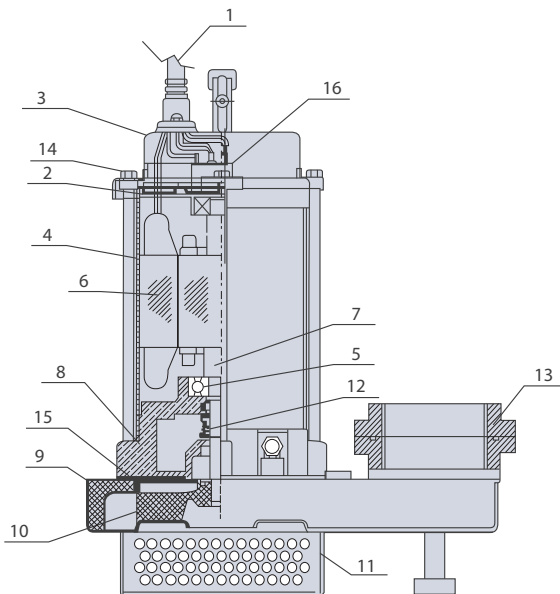

NO.	名称	Name	材质
1	电缆	Cable	VCT
2	轴承座	Bearing cover	SUS304
3	马达盖	Motor cover	SUS304
4	马达本体	Motor casing	SUS304
5	轴承	Bearing	NSK(or SKF)
6	定子	Stator	F Class
7	主轴	Shaft	SUS410
8	中承轴	Bracket	PP
9	泵浦本体	Pump casing	PP+SUS304
10	叶轮	Impeller	PP
11	滤底座	Strainer	SUS304
12	机械密封	Mech.seal	Carbon/Silicon
13	法兰	Flange	PP
14	螺标	Bolt	SUS304
15	垫片	Bracket gasket	PP
16	过热保护器	Thermostat	-

## 性能表 Specifications

型号 Type	电机 Motor						泵浦 Pump					重量 Weight (kg)
	功率 (kw) (HP)	相数 Phase	电压 Voltage	极数 Pole	频率 (Hz)	口径 Disch.Dia (mm) (in)	扬程 Head (m)	流量 CAP. (l/min) (m <sup>3</sup> /h)				
SSP-50.4-50(S)	0.4	0.5	3(1)	220/380	2	50	50	2"	7.5	150	9	11.5
SSP-50.75-50(S)	0.75	1	3(1)	220/380	2	50	50	2"	10	220	13.2	14
SSP-51.5-50	1.5	2	3	380	2	50	50	2"	14	265	15.9	15.5
SSP-51.5-80	1.5	2	3	380	2	50	80	3"	14	340	20.4	19
SSP-52.2-80	2.2	3	3	380	2	50	80	3"	15	450	27	22
SSP-53.7-80	3.7	5	3	380	2	50	80	3"	20	550	33	24

## 性能曲线 Performance curve

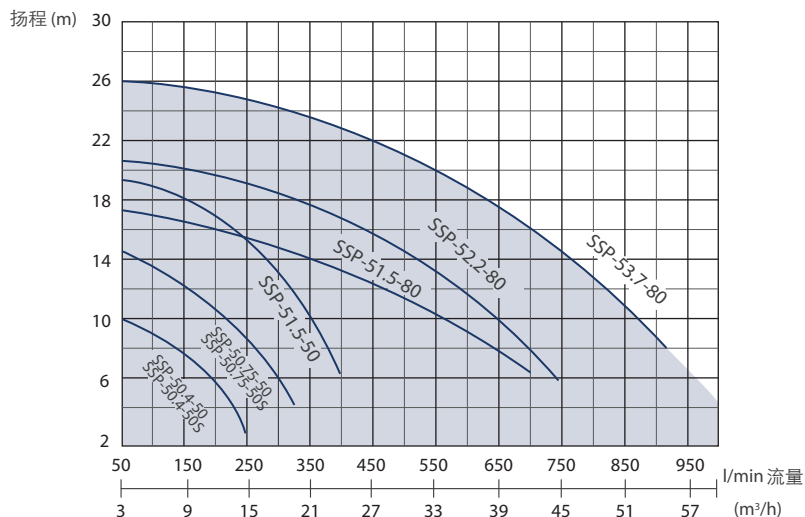

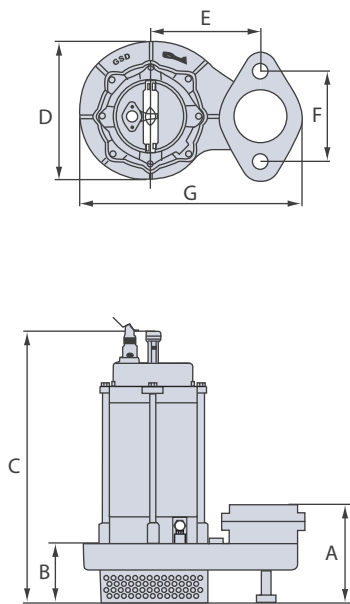

FIG.1

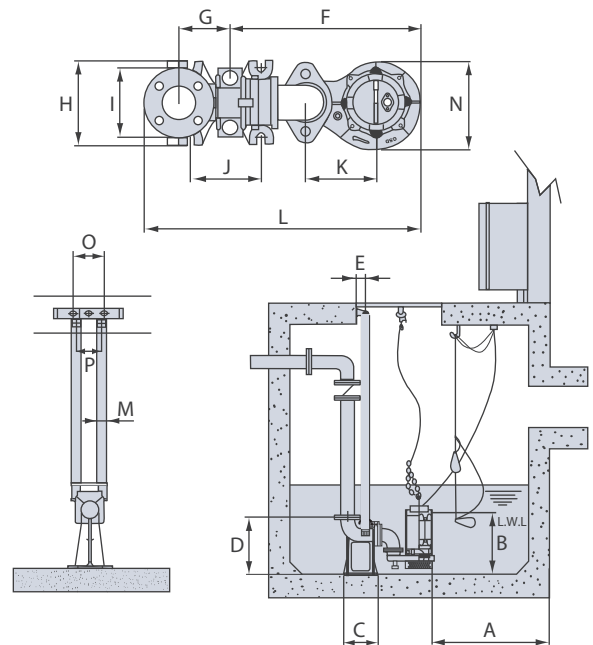

FIG.2

## 无着脱式外形尺寸(FIG.1) Dimensions (without autoserter)

(mm)

型号 Type	A	B	C	D	E	F	G	型号 Type	A	B	C	D	E	F	G
SSP-50.4-50S	138	85	395	190	122	98	257	SSP-51.5-50	138	85	463	190	122	98	257
SSP-50.4-50	138	85	395	190	122	98	257	SSP-51.5-80	163	100	438	230	180	150	362
SSP-50.75-50S	138	85	463	190	122	98	257	SSP-52.2-80	163	100	458	230	180	150	362
SSP-50.75-50	138	85	423	190	122	98	257	SSP-53.7-80	163	100	498	230	180	150	362

## 附着脱式外形尺寸(FIG.2) Dimensions (with autoserter)

(mm)

型号 Type	A	B	C	D	E	F	G	H	I	J	K	L	M	N	O	P
SSP-□□-50	>1500	355	180	310	59	318	130	150	120	110	122	512.5	25A	190	140	135
SSP-□□-80	>1500	415	226	434	59	458	163	220	180	180	180	713	25A	230	140	135

免费咨询电话

**400-657-9066**

本型录内容如有变更，恕不另行通知。  
We reserve the right to change content without notice.

